



FRP & POLY TANKS –  
THE PERMANENT ALTERNATIVE

**THE NAME SAYS IT ALL...**

To ensure a long trouble free life for your tank please follow the recommended methods of installation. If you should have any queries regarding these or other methods of installation please do not hesitate in calling our office.

## Tank Installation and Site Preparation

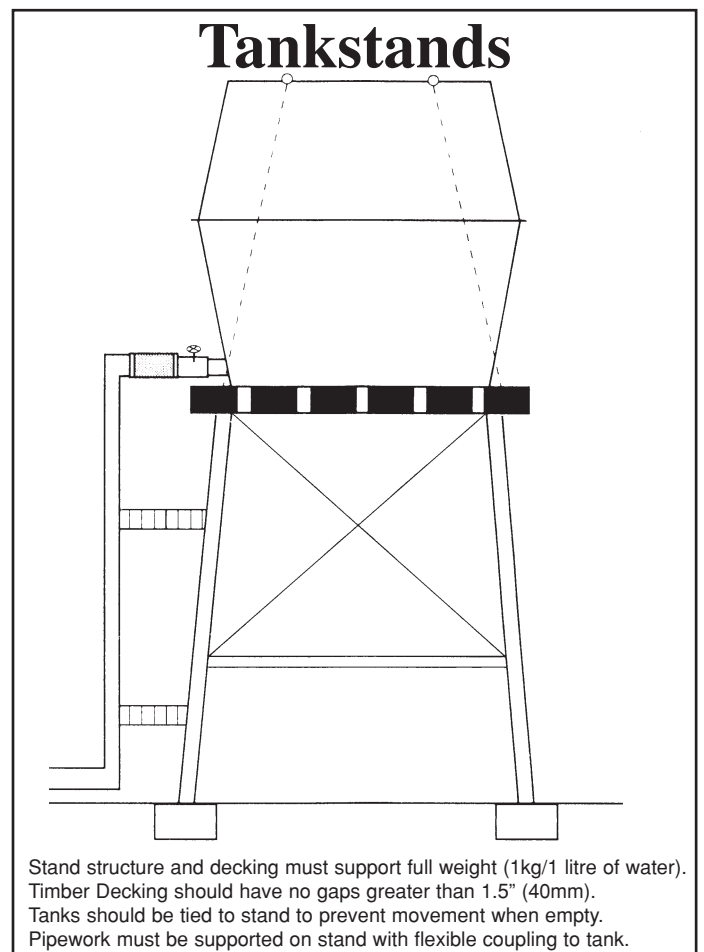
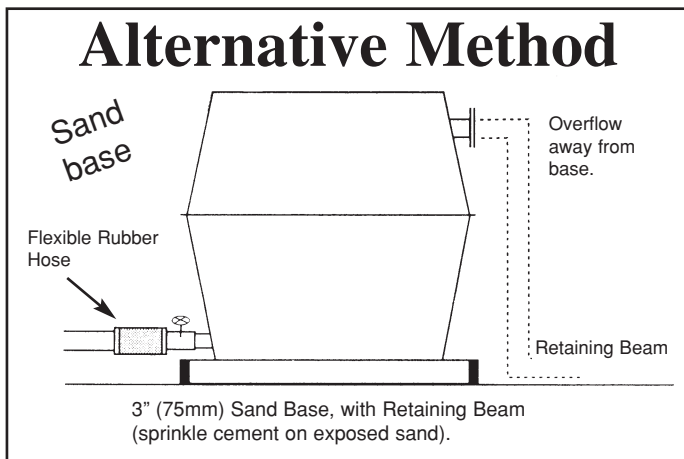
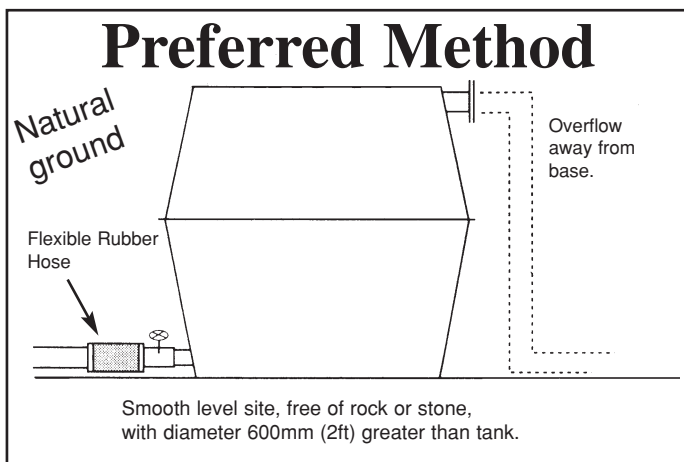

## Critical Points to Remember

1. Base of tanks must be supported across its entire area (base support must remain flat at all times). The site must be fully maintained throughout the tanks lifespan.
2. Pipe work should not place any loading on tank wall (flexible coupling is best alternative).
3. Overflow size must equal or exceed inlet size.
4. Tank must be vented to prevent it being subject to pressure or vacuum (leafstrainer or breather must be installed).
5. Tie your tank down upon delivery.

# TANKWORLD

## WARRANTY

**TANKWORLD** Tanks have a warranty to the original purchaser for a period of Ten years against faulty workmanship or materials provided the following is carried out:

- Do not roll the tank on the flange. (F/Glass)
- Tie down tank on delivery.
- Overflow must be piped away from the base.
- If a sand fill base is used, a retaining beam must be provided to stop sand washing away.
- The number of inlet pipes, their sizes and capacities must equal the number of overflow pipes, their sizes and capacities.
- Correct tank site preparation, as well as preservation is the sole responsibility of the purchaser.
- Do not allow the tank site to deteriorate after installation, due to any form of corrosion.
- Tank outlets must not be subjected to any undue force.
- The period of ten years (warranty) is for water tanks and five years for other products, commences from the date of purchase.
- The Warranty is limited to replacement or repair of the tank.
- The warranty is granted to the original purchaser only and is not binding on any heirs or successors in title thereof.
- The manufacturer will not be liable for any consequential losses including loss of profits or damage to property.
- The warranty does not apply to the colour which may fade or change.
- The warranty is void and will not be binding upon the manufacturer where any physical abuse, improper installation, unsound base, or unauthorised modifications have occurred to the tank. PLEASE NOTE: The tank must have 12" flexible hose fitted; as per diagrams contained herein.
- The warranty is only binding upon the Manufacturer if notified of the defect or fault within seven (7) days of it occurring and where the manufacturer has been given the opportunity to inspect the tank within twenty-eight (28) days of such notification.
- The warranty on strainer, outlet, gate valve and overflow is 12 months only.
- Tanks purchased for the purpose of ambient water storage are restricted to that purpose only. Storage of any other materials in the tank will void this warranty.
- Tankworld truck drivers are employed to deliver water tanks to your property, they are to (where physically possible) place the tanks onto a flat, level site which should be provided. They are to cut in an outlet and overflow. Any duties other than the above carried out by the driver at the customer's request is the sole responsibility of that customer, NOT the driver or Tankworld.
- The purchaser acknowledges having fully read and understood the contents of this warranty and agrees to be bound thereby. A docket will be produced upon delivery for you to sign, to acknowledge all of the above. This must be signed and returned within 28 days, or all warrantees will be null and void.

### VICTORIA & SOUTH AUSTRALIA

PO Box 1389  
135 Karinie Street  
SWAN HILL 3585  
Phone: (03) 5033 1155  
Fax: (03) 5033 1213  
Free Call: 1800 68 69 70

**TANKWORLD**

ABN: 58 273 136 788

### NEW SOUTH WALES

PO Box 581  
17R Yarrandale Road  
DUBBO 2830  
Phone: (02) 6882 0944  
Fax: (02) 6884 1370  
Free Call: 1800 80 06 26

**TANKWORLD**

ABN: 54 003 305 137

### TASMANIA

PO Box 471  
Airport North, Main Road  
WESTERN JUNCTION 7249  
Phone: (03) 6391 8050  
Fax: (03) 6391 8051  
Free Call: 1800 65 66 67

**TANKWORLD**

ABN: 68 282 187 801